

BUNDUTOP  
www.bundutop.co.za



# BUNDUTOP

MANUAL

---



PROUDLY MANUFACTURED  
IN SOUTH AFRICA

# BUNDUTOP



## Please familiarise yourself with this manual, as proper use of this product is directly linked to the warranty.

The BunduTop standard size is

2100 x 1350 x 300 mm when closed,

and 2100 x 1350 x 1070 mm when open.

**PLEASE NOTE** you can order a custom sized BunduTop up to 1.6m wide and 3.1m long.

The tent weighs about 73 kgs, and the ladder 7kgs.

The tent boasts entry from any side, giving you 360° access and view. Each window/door is manufactured with the canvas on the inside and the mesh on the outside. This allows you to leave the windows open for ventilation, even in poor weather conditions

The BunduTop comes standard with an aluminium sliding ladder and 2 pockets inside to put keys, cellphones etc. and has a cigarette lighter plug and an LED light inside.

The roof of the BunduTop is a raw aluminium sheet to ensure maximum heat reflection and is the main reason you can sleep comfortably cool inside, even in direct sunlight.

The roof weighs 20 kgs and can carry additional weight of 25 kgs, if evenly spread.

You are welcome to install a solar panel on top. We include solar wiring and it simplifies the installation of a solar panel by allowing the wiring to go unseen through the tent.

The 2000lbs winch motor lifts and lowers the tent with the use of 3mm Dyneema rope on a pulley system.

The foam-backed roof-lining absorbs moisture and condensation, but if you are going to extremely cold areas we do recommend putting a carpet under the mattress as insulation, as very cold temperatures creates additional condensation.

The frame built into the bottom of the tent provides additional strength and makes it versatile to mount. It can be bolted directly to your load bars or roof rack.

The mattress inside is 2000 x 1250 x 100 mm and is made from a high density foam. A double bed fitted sheet fits it just fine. This leaves enough space inside the tent so that you can leave your bedding inside.



**DO NOT OPEN THE TENT WHILE THE LATCHES ARE STILL CLOSED AS THIS WILL DAMAGE THE TENT.**

Kindly arrange your bedding so that it can't hook into the rope system inside; flattened bedding won't interfere.

Please ensure you leave the windows open or close only the mosquito net so that trapped air can escape. Trapped air will push out the canvas sides and cause it to not fold in properly when lowering the tent.

When entering or exiting the tent, ensure that the zips are completely zipped down as the zips/mosquito net isn't designed to carry weight.

The tent has been tested extensively in various locations and weather types. In the USA it has proven to withstand 50 mph winds and has also performed well in snow.

In locations with extreme humidity and heat, the combination can cause extreme condensation inside the tent. This will be UNDERNEATH the mattress. If you are experiencing similar conditions, try to ventilate the tent to prevent the condensation.

**PLEASE NOTE** that when using the tent for the first time the canvas can be stiff.

It gets coated with various resins to ensure its longevity and UV qualities, so when first operating the canvas has no "memory" how to fold. After a couple of uses the canvas will develop a "memory" of how to fold and the folding will become neater and easier as time passes.

The initial folding process will seem stiff but with time it will ease into its shape and fold neatly.

## INCLUDES

### It boasts:

- Full electric operation
- Shade and rain awning around all four sides of the tent
- Tent fully erect, with awnings, in 30 seconds at the press of a button.
- Tent fully closed, all sides & awnings folded away in 30 seconds at the press of a button
- 2100 x 1350 x 300 mm closed & 2100 x 1350 x 1070 opened
- Window covers zip open/closed from the inside
- Insulated roof inside
- All aluminium construction
- Stainless steel supports:
  - The tent has an existing aluminium frame built into the bottom.
  - If replaced with stainless steel the frame can accommodate an overhang of up to 500mm.

### Includes:

- 100mm high density foam mattress - 30 density , 16 hardness
- 12V outlet inside
- LED light inside
- All aluminium construction ladder

### Solar Wiring:

- Since 2017 we incorporated solar wiring as a fixture with every BunduTop.
- The wiring for the solar panel runs underneath the roof-lining.
- There will be a red Brad Harrison plug on the roof of the tent for easy connection to your solar panel.
- There will be a red Brad Harrison plug on the bottom of the tent for easy access to your vehicle's wiring.
- Please remember when mounting a solar panel that the max weight is 25 kgs and the weight needs to be evenly spread – make sure the supports run the entire length of the roof.



**PLEASE ENSURE THAT NO BEDDING OBSTRUCTS THE ARMS WHEN CLOSING YOUR TENT.**  
**ALSO, PLEASE ENSURE THAT THE WINDOWS ARE LEFT OPEN WHEN CLOSING YOUR TENT SO THAT AIR CAN ESCAPE.**

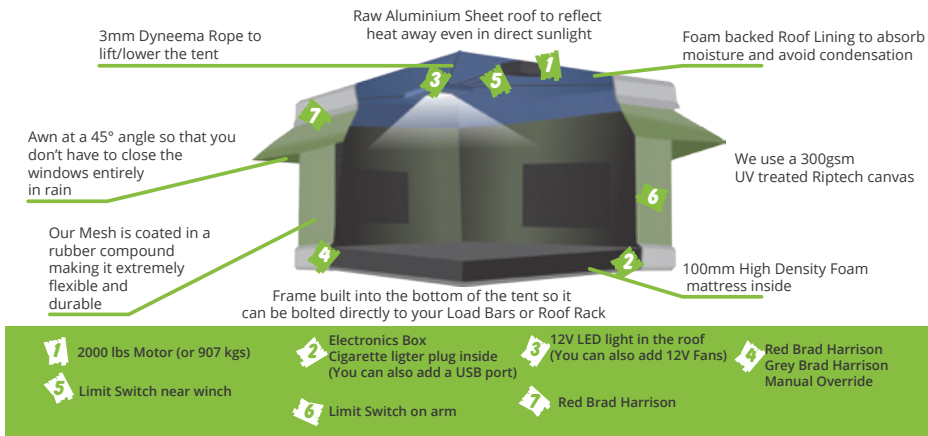

## Extras

- Added room
- USB port
  - If you prefer we can add a USB port to your rooftop tent.
  - It will be accessible from inside.
- 12V fan
  - As an additional extra you can add 12V fans.
  - They can be switched on and off with their own individual switches from inside the tent. The wiring for the fans also run underneath the roof-lining.

## Pros & Cons

### Pros:

- Lifts or lowers at the touch of a button
- Leave bedding inside
- Rigged for solar panels
- Has an LED light and cigarette lighter plug inside
- Comes with our all new double sided ladder – you can specify round or square
- Weighs approx. 80 kgs

### Cons:

- Takes up a lot of roofrack space

## Operating the Tent

12v Power Connects to vehicle's dual battery system.

Solar Wiring Connects to vehicle's regulator.

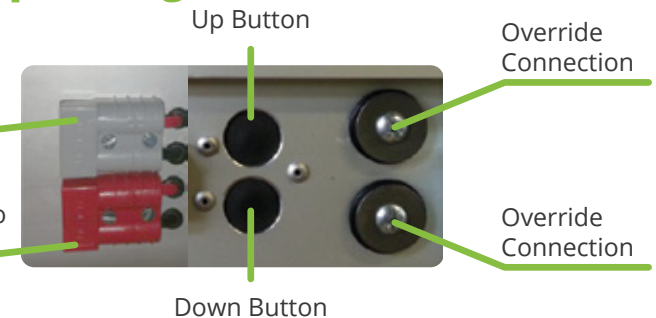

## How does it work?

The tent has a winch inside that lifts and lowers it. It is connected to ropes that run on bearings to effectively pull in the awnings and sides. The rope system inside is essentially dyneema plasma rope snaked through various pulleys and arms, as well as the mechanisms for the awning to pull in the sides and awnings when the tent is shut.

The arms and their unique design again assist with the lifting of the tent and ensures that it is rigid when open, essentially strengthening the construction.

Unclip ALL FOUR latches and ensure that they are open before pressing the button to lift the tent. There is a safety feature (limit switch) that assists with telling the motor when to STOP while lifting/lowering the tent. YOU, however, are responsible for telling the tent when to START, so kindly ensure all the latches have been opened.

Should you forget to unclip one of the latches the arms inside could bend. It is also the only way to damage the tent from the inside. It is easy enough to fix but best avoided.

We will also be able to tell whether this was the cause, so better to be honest when taking it in for repairs!

**OUR TENTS HAVE A ONE YEAR MECHANICAL WARRANTY.**

## The Electronics

All the electronics used in the BunduTop can be found inside the Electronics Box which houses:

- The Switch
- The Manual Override
- 1 x Relay – 2 x Automotive Relays
- 1 x Lighter Socket

Should you experience any difficulties with your tent's wiring, this is where everything is located.

### Electrical Override:

Up – Open  
 Positive top  
 Negative bottom

Down – Close  
 Negative top  
 Positive bottom

Electrical override serves as a backup should you experience any faults in the electrical system of the tent. The override completely bypasses the electronics and serves as a power source directly to the winch motor inside the tent. This means the tent won't know when to stop when you open or close it. You have to stop it lifting by removing the electrical flow just before the canvas is taut. The same will apply when you lower it this way. When the tent is about 1cm away from being completely shut, remove the electrical flow. You can simply pull down the roof the last cm and fasten the latches. When overriding your tent, the positive flow will dictate direction. To open the tent, the flow will be positive on the top override and negative on the bottom. To close the tent, the flow will be negative on the top override and positive on the bottom.



COVERED: Location of electronics cover inside tent



UNCOVERED - Switch, wiring and relays

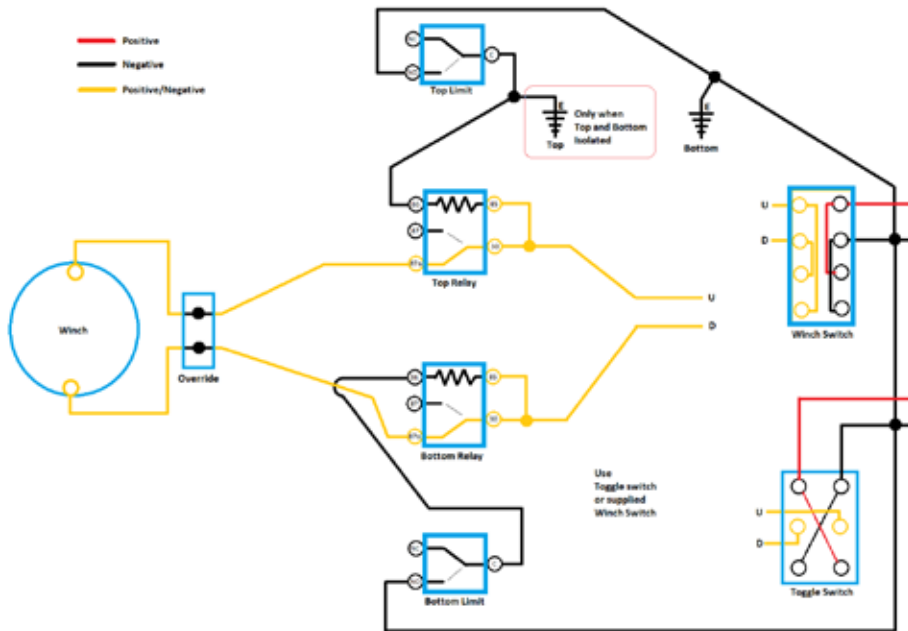

## Electrical faults and how to pinpoint them

### The Limit Switches:

The Limit Switch located near the winch tells the tent when to stop lowering. The Limit Switch on the arm tells the tent when to stop lifting. The Limit Switch on the arm tells the tent when to stop lowering. **NEVER** adjust these switches unless instructed otherwise by a technician.

**PLEASE NOTE** that it is preferable to connect your tent to the secondary battery.

**PLEASE NOTE** that depending on what solar panel you have installed, you need to install a regulator that can handle VOLTS and WATTS. A lot of smart systems can handle 28V but not the 45V that a 300W Solar Panel produces.



Location of Limit Switch near the winch motor



Location of Limit Switch on the arm

## How do I fit the tent myself?

When installing the tent, we advise that there is no more than a 0.5m unsupported overhang.

We also advise that the roofrack/load bars should be no less than 1.27m wide.

If installing on load bars, use three evenly spaced supports. The tent can be bolted on with a minimum of 4, but preferably 6, bolts and you can run wiring from the dual battery system with a Brad Harrison plug through the vehicle or make an extension.

**NO LIMIT SWITCHES WORK WHEN YOU OVERRIDE THE TENT MANUALLY. BE CAREFUL TO STOP THE LIFTING/LOWERING IN TIME.**

### BOTTOM FRONT VIEW

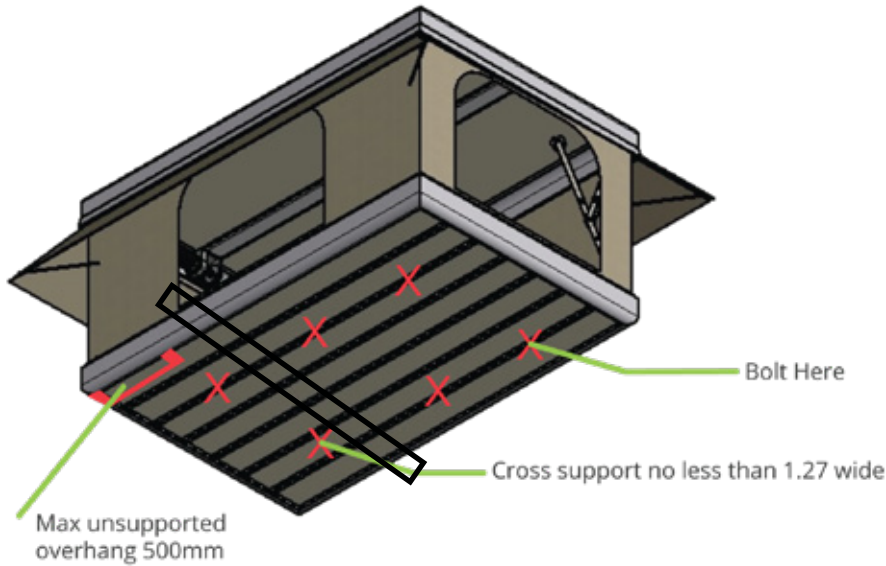

### UNDERSIDE OF TENT

If you are doing the wiring from your battery directly to the tent:

- Use a Brad Harrison plug
- Use 6 mm<sup>2</sup> electrical wire
- Use 15 Amp inline fuse – This is an electrical safety and will help minimize damage if you forget to open the latches
- Make sure to connect positive and negative correctly.

**PLEASE NOTE** that a larger fuse is not a good idea. The purpose of the inline fuse is to blow when the tent pulls too many amps.

This means that if you accidentally left a latch on, the tent's motor will work harder to lift the roof, thus pulling more amps and therefore blowing the fuse.

After the fuse blows the tent will come to a standstill and thus safeguard against bending the arms or snapping the ropes inside.



#### Quick Tip:

Some Dual Battery systems already installed may have a low amp rating. When lifting the tent the system detects a high current draw on the load output leading to the tent and cuts off the power. If connecting to these type of systems please make sure that the output can accommodate the amps required by the tent.

**PLEASE NOTE** that if opening the tent for the first time for installation and the wiring is not made up yet, use the electric override option to open tent and be careful to not over tighten the tent.

#### Electrical Override

Up - Open	Down - Close
Positive Top	Negative Top
Negative Bottom	Positive Bottom

If installing on load bars use three evenly spaced supports.

#### Remember to mount the ladder bracket:

After installing the tent, mount the ladder bracket beneath the opening you will be using as the door. This way the ladder has a place to hook on to and will be less damaging than simply hooking the ladder onto the lip of the tent.

- 1 Hold the bracket in position on the side of the tent where you will be entering your tent.
- 2 Trace the outline
- 3 Mark where you want to place your rivets and drill the holes
- 4 Hold the bracket in place again and rivet the bracket to the tent's side.
- 5 Repeat steps for the other bracket.

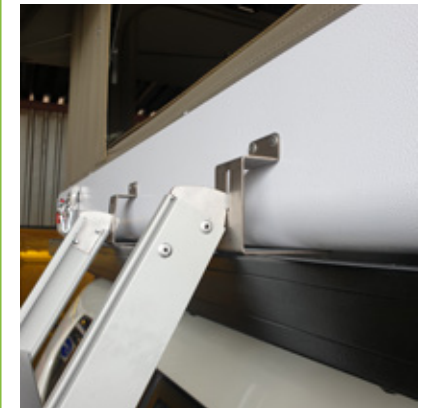

#### After Fitment:

After installing the tent it is a good idea to check for symmetry when lifting/lowering.

You can fine-tune how evenly the roof lifts/lowers by adjusting the turnbuckles. If you screw them in the roof will lift, if you screw them out the roof will lower – you have about 5cm to work with.

## How to install a Solar Panel

**PLEASE NOTE** to be careful when drilling through to the inside of the tent as the drill bit might catch on the roof-lining and cause tears. Also ensure that the holes are properly sealed to insure that it is still dust/water tight.

The support rails that your solar panel will be fitted to must run the entire length of the roof. If the weight is not distributed from end to end, the weight of the solar panel will dent and damage the roof, which may break the seal and cause leaks.

## How to add Solar Wiring afterwards

Add a Brad Harrison plug next to your current grey plug on the bottom frame. Add a Brad Harrison plug to the top frame. Connect the two with 6mm wiring that can go through the inside of your BunduTop – ensure the length is long enough. To neaten the appearance, you can run it through the canvas sleeve next to the arm that already contains wiring.

Please note that since the end of 2017 all tents are manufactured with solar wiring so the below will only be applicable as an upgrade to older tents

## How to add Fans and lights afterwards

You can order the 12v Fans or LED lights from the factory to install afterwards. The frames they come in have a clear aluminium area that gets fastened to the interior roof of the tent. Firstly decide on placement and remove the roof-lining with a blade – this ensures that when you drill the holes to rivet/bolt the fan/light to the roof the drill bit does not catch on the material and cause tears

Kindly use the wiring diagram as reference

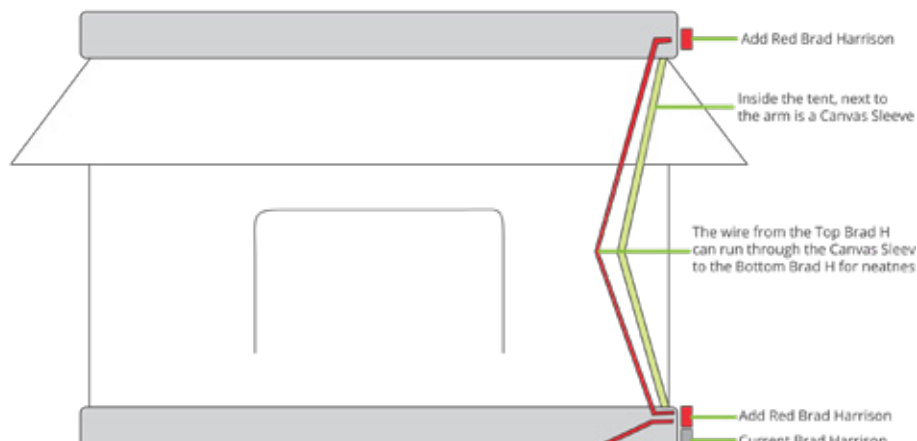

To hide wires you can run them underneath the CANVAS edging around the tent – merely lift this edging, run the wiring through and glue down neatly again (you can use the canvas sleeve in the arm to hide any additional wiring).

**PLEASE NOTE** that this can affect the warranty of the tent if not to professional standards.

## Maintenance

While unnecessary when not experiencing any faults, we do recommend maintenance in the older tents, as designs are upgraded continuously. This can be done by just replacing the ropes and re-aligning the roof.

### How to replace the Ropes:

- Remove old ropes (remember to leave one arm as is as a reference when you do the new ropes).
- If the tent has turnbuckles, turn them so that they are adjusted with half of the thread showing inside and outside the turnbuckle. If the tent has the adjustment bolt, leave as is for fine tuning.
- Roll the belt onto the barrel until about only 100mm is left.
- Snake the rope through the 4 holes in the belt, the ropes have to go through the correct bearings in the roof.
- There are 4 bearings in the middle of the roof under the light cover, left bearing is for left far side, second to left bearing is for is left front and the other two mirror for the right.
- Snake the rope through the arm mechanism as per the copy you left intact.
- Tie the rope to the turnbuckle or Thread through the hole in the adjustment bolt or tie the rope to the turnbuckle, preferably hangmans noose, otherwise just a proper knot.
- Begin at the belt and tighten the rope through its course, the roof of the tent will lift – just keep going until the canvas is nice and taught and tie the rope off at the belt. Repeat for each arm.
- You can fine-tune how evenly the roof lifts/lowers by adjusting the turnbuckles or the adjustment bolt. . If you screw them in, the roof will lift, if you screw them out the roof will lower – you have about 5cm to work with.

If you need to lift/lower more for an even roof you need to adjust the rope at the belt area again.

## Repairs

The only other faults we have experienced are the following:

- 1. Tent does not go up or down.**
  - Check that the electric cord to the tent has power (if the light goes on inside the tent then there is power).
  - Check that the connectors are not corroded (if the connectors are corroded it will not allow enough current through to drive the winch).
  - Use the electric override if all else fails.
- 2. Tent opens but does not close.**
  - Check the limit switch near the winch.
  - The arm on the limit switch might bend over time and not make contact. Bend the arm a little bit down so that the switch makes contact when the belt is tight. When the tent closes and the belt gets slack the switch will disconnect and stop the winch.
  - Use the electric override if all else fails.

The other main fault we have experienced is the customer accidentally forgetting to open the latches. The ropes should snap before any serious damage can be done, but we have had instances where the arms are bent. In this case you can either straighten out the arms after removing them or get replacements from the factory. You may have to replace the safety belt on the winch motor if the ropes damaged the edge of the belt.



**If your tent opens, but does not close, the limit switch could have been bent by bedding. Please follow the instructions in point number 2.**

**If you are replacing the belt:**

- Remove old belt and ropes (remember to leave one arm as is as a reference when you do the new ropes).
- Turn the turnbuckles so that they are halfway in and halfway out (about mid way).
- Drill out the 2 old rivets from the barrel of the winch.
- Paint adhesive glue on the 100mm front section of the belt and paint adhesive glue on the barrel of the winch.
- Give a few minutes to air dry to ensure maximum stickiness, then re-rivet the belt to the winch.
- The belt has to go over the top of the barrel (between the winch and the tent's roof).
- Follow the rest of the instructions under "Maintenance".

## FAQ

**What is it made from?**

The tent is full aluminium construction and a durable Riptech canvas. The tent seals completely when closed and gives a full dust and waterproof seal.

We use a 300gsm Riptech canvas that is UV resistant to prevent fading. The wrap-around awning is at a 45° angle so that you can have ventilation in poor weather with maximum water deflection. Our mesh is coated in a rubber compound making it extremely flexible and durable.

The roof of the BunduTop is raw aluminium sheet to ensure maximum heat reflection and is the main reason you can sleep more comfortably cool inside even in direct sunlight.

The 2000lbs Winch Motor lifts and lowers the tent with the use of 3mm Dyneema Rope on a pulley system.

The foam-backed roof-lining absorbs moisture and condensation but if you are going to extremely cold areas we do recommend putting a carpet as insulation under the mattress as very cold temperatures creates additional condensation.

The frame built into the bottom of the tent provides additional strength and makes it versatile to mount. It can be bolted directly to your load bars or roof rack.



**Quick Tip:**

**Taking care of your canvas is easy! Gently wash with a mild detergent and water. Avoid excessive scrubbing or abrasion.**

**Can I fit the tent myself?**

Yes. It is not heavy, but it is an awkward shape and will need atleast 2 people to handle.

**What if it doesn't work?**

Should you experience electrical failure the tent will be the least of your worries. (Those beers will be getting warm!)

Even so, the tent has a manual override outside, situated right next to the buttons used to lift/lower the tent.

Electricity in the form of a Brad Harrison connection can be used to lift/lower the tent this way. It came with your tent upon purchasing it.

You can simply pull down the roof the last centimeter and fasten the latches.

**What if I accidentally broke it by forgetting one of my latches on?**

It will still work.

The roof of the tent (which weighs +/- 20 kg) can be easily lifted by one person, who can crawl inside and wedge the corner arms in place. You may need a cable tie to tie them into that position. When you lower it the next morning gravity will step in and lower it for you and the sides and awnings will still pull in.

**The holes in my tent doesn't have eyelets in them.**

The eyelets don't wear well. The holes are actually burned into the canvas, because it's the strongest way to make the holes. While eyelets make for a better finish, it does not make for a stronger one, and our research suggests that eyelets pose as a weak point and is generally where tears can originate.

This is caused by the crimping tool used to install the eyelet, causing it's metal edges to essentially cut into the material it's being installed in, weakening the material on those points.



## LIMITED WARRANTY TERMS

### What Is Covered

BunduTec (Pty) Ltd warrants to the original purchaser that its products are free from defects in material and workmanship, for the term described, except as qualified below. The life of the product is determined from the date of purchase until such time as the product is no longer serviceable due to normal wear and tear.

### What Is Not Covered

BunduTec (Pty) Ltd shall not be responsible for the natural breakdown of materials that occurs inevitably with extended use (e.g., Ultra Violet (UV) light damage on tents, exhausted zippers), or defects caused by accident, abuse, alteration, animal attack, storm damage, misuse or improper care.

There are no other express warranties beyond the terms of this limited warranty. In no event shall BunduTec (Pty) Ltd be liable for incidental or consequential damages.

### What BunduTec (Pty) Ltd Will Do

If, after inspection, we find that a product failed due to a manufacturing or material defect, we will repair or replace the product, at our option, without charge.

### How To Obtain Warranty Service

Return the product, freight prepaid, to the BunduTec (Pty) Ltd dealer from whom it was purchased; or, contact BunduTec (Pty) Ltd's Customer Satisfaction Department for return authorisation on 063 872 7667. Collect shipments or shipments without return authorisation cannot be accepted.

### Repairs

If your BunduTec (Pty) Ltd product needs service or repair due to normal wear and tear, animal attack, accident or some other reason that is not covered under the warranty we will provide the necessary service for a reasonable charge, plus shipping and handling. We require that products accepted for any repair be properly cleaned according to our recommended care instructions. Please send your product or component that requires repair, postage prepaid, along with a description of what needs attention. For service and repairs, please contact our Customer Satisfaction Department on 063 872 7667.

### Warranty Term

Limited two-year warranty applies to all tent components including aluminium base, aluminium extrusions, aluminium arms, ladder, canvas and seams.

### There are patches on my tent.

This is simply a strengthening patch placed to ensure that your canvas is enforced on places that take more strain.

### Can I add extras?

You can add fans, a USB port, stainless steel supports, an added room and a solar panel. A mattress, ladder, LED light and lighter socket are already installed.

### If I put a thicker rope inside will I be able to lift heavier things on the roof?

No. It is designed to cater for solar panels only.

### Can you provide me with a thicker mattress?

Unfortunately, we don't carry various stock, but if you would prefer a different mattress let us know when ordering and we will exclude the mattress - that way you can source another mattress better suited to your needs. The maximum thickness allowable is 120mm.

### Can I add extra lights inside?

You can add additional lights inside the tent when you place your order.

Also note that the light situated inside is bright enough to read by and no additional lighting is necessary.

### Can I add fans inside?

You can add fans inside the tent when you place your order. Adding them at a later date might result in damaged roof-lining inside your tent.

Also note that the tent was designed to reflect heat away and the big windows allow maximum airflow, therefore adding a fan will improve airflow and is great in conditions where there is no wind.

### Can I order a bigger size?

You can definitely order a larger sized tent!

Please note that this severely affects the price as we have special extrusions that make up the shell of the tent. One extrusion equals one standard tent.

When we make a larger tent we charge for an additional length of extrusion as there will be off-cuts which can't be used again for another tent.

### I don't want round rungs on my ladder.

We have recently upgraded our ladder design to feature a double-sided ladder design, which can be utilised either way. Should you require a rounder profile you can use it one way, and should you prefer a square profile you can use it the other way.

Ladders MUST be locked at optimum height / angle. By putting all of the weight on the tent alone it could cause damage to the shell. Rather have the ladder carry the weight.

All of our rungs feature grooves as an added anti slipping measure.

If you would prefer a different ladder, kindly let us know when placing your order and we will exclude the ladder - that way you can source another one better suited to your needs.

### Will the shape of the tent affect my fuel consumption?

Yes, and it depends on where the tent is mounted; if more forward on the roof it will have a greater effect. There are also variances depending on your vehicle type + brackets.



# CONTACT US

By phoning the office, Front Desk can follow up on all calls and make sure they are attended to.

## South Africa

### BunduTec

**Tel:** +27 6 3872 7667

**Email:** [info@bundutec.co.za](mailto:info@bundutec.co.za)

*Manufactured in South Africa*

## Australia

### Bundutec Australia

**Tel:** +61 414 500 430

**Email:** [sales@bundutec.com.au](mailto:sales@bundutec.com.au)

## United Arab Emirates + Oman

### The Great White

**Tel:** +97 15 0350 2735

**Email:** [hello@tgw.ae](mailto:hello@tgw.ae) | [mksbusinesswork@gmail.com](mailto:mksbusinesswork@gmail.com)

## Europe & United Kingdom

### Tuff-Trek Ltd

**Tel:** +44 078 6329 5172

**Email:** [dara@tuff-trek.com](mailto:dara@tuff-trek.com)

## Israel

**Tel:** +972 544 320 777 | +972 545 700 445

**Email:** [www.bundutec.co.il](http://www.bundutec.co.il)

## Namibia

### Offroad Center Windhoek

**Tel:** +26 4 6123 7532

**Email:** [offroad@afol.com.na](mailto:offroad@afol.com.na)

## Bushwhackers Campworld Swakopmund

**Tel:** +26 4 6440 0396

**Email:** [swakop@nambush.com](mailto:swakop@nambush.com)

## Bushwhackers Windhoek

**Tel:** +26 46 125 8760

**Email:** [simon@nambush.com](mailto:simon@nambush.com)

## United States of America

### BundutecUSA,

**Tel:** +1 319 234 0071

**Email:** [rory@bundutecusa.com](mailto:rory@bundutecusa.com)

## Canada

### Wild Coast Camping Gear

**Tel:** 902 467 0250

**Email:** [rtt@wildcoasttents.com](mailto:rtt@wildcoasttents.com)

## BunduTec Botswana

**Tel:** +267 75 955 577 | +267 74 725 211

**Email:** [info@bundutec.co.bw](mailto:info@bundutec.co.bw)

